

SONY

Sony Product Bulletin

BRC-H700P.PIL.V1, 10th Jan 2006

Product Information Letter BRC-H700P

- Product Information Letter -



BRC-H700P

Sony's New Remote, Multi-Purpose HD Camera System.

www.sonybiz.net/media



Table of Contents

Section	Title	Page
1	Introduction	4
2	Main Features	5
2.1	Stylish and Robust body with HD 3CCD	5
2.2	Wide Angle and High Accurate Pan/Tilt Mechanism	5
2.3	48x Zoom Ratio (12x Optical, 4x Digital)	6
2.4	Ceiling Mounting and Image Flip Function.	6
2.5	Preset Memory Function.	7
2.6	RS-232C/RS-422 Serial Control by VISCA.	7
2.7	Preset Memory and Default Value.	8
2.8	RS-232C/RS-422 Serial Control by VISCA™	10
2.9	External synchronization capability	10
2.10	Camera control function	10
2.10a	Electric Shutter Speed	10
2.10b	Spot Light	10
2.10c	Backlight Compensation	10
2.10d	White Balance	10
2.10e	Aperture Control	11
2.10f	Hyper Gain	11
2.10g	Skin tone Level	11
2.10h	Cinema tone Gamma	11
2.10i	ND filter	11
2.10j	Image Stabilization	11
2.10k	Colour Bar	11
2.11	Multi-function IR Remote Commander® unit	12
2.12	On-screen menu	12
2.13	VISCA address setting	12
3	BRU-H700 Interface unit	12
3.1	Uncompressed digital transmission	12
3.2	Variety of video signal output	12
3.3	RS-232C/RS-422 Serial Control by VISCA™	13
4	BRBK-H700 Multiplex option board	13
4.1	HD Optical Multiplex Card	13
4.2	Audio Line Input	13
5	CCFC-M100HG	13
5.1	HD Optical fibre cable	13
6	Sales Points	14
7	Applications	18
7.1	Remote TV Production	15
7.2	Corporate	15
7.3	Governmental and Industrial	16

SONY

7.4	Events Recording and Production	17
7.5	Point of View	17
8	System Configurations	18
8.1	Simple Operation Using the Remote Commander	18
8.2	Simple Operation Using the Optical Multiplex Unit.	19
8.3	Long Distance Operation Using Multiple BRU-H700.	20
8.4	Audio Configuration.	21
9	Main Menu Overview	22
9.1	Menu functions unique to BRC-H700	23
9.2	Option card menu overview.	23
10	Dimensions.	24
10.1	BRC-H700	24
10.2	BRU-H700	25
11	Rear Panel Overview.	26
11.1	BRC-H700	26
11.2	BRU-H700	26
12	Specifications.	27
13	Optional Accessories	29



1.Introduction.

Sony introduces the new BRC-H700 HD Colour Video Camera with three 1/3-inch type HD CCDs boasting 1,070,000 effective pixels each for high resolution and high sensitivity.

The BRC-H700 is an all-in-one compact robotic color video camera system, which achieves high accuracy and wide-range Pan/Tilt/Zoom performance without complicated cable connections and installation. With the optional Sony RM-BR300 Remote Control Unit, featuring an ergonomically designed joystick, the BRC-H700 can be precisely controlled via the camera's control interface (RS-422 or RS-232C) using the VISCATM protocol.

When using the optional BRU-H700 HD Optical Multiplex Unit and optional BRBK-H700 HD Optical Multiplex Card in the camera, this system allows users to control the cameras and transmit digital image data and audio signals from a distance of up to 1,000 meters away via optional CCFC-M100HG Optical Fiber Cables. In this configuration, up to seven cameras can be controlled with a single RM-BR300 by daisy chaining the BRU-H700 HD Optical Multiplex Units via the control interface using VISCA protocol.

The BRC-H700 comes equipped with a card slot that accepts a variety of optional interface cards, making it compatible with a number of different systems. The interfaces supported with these optional cards include HD-SDI, SD/SD-SDI (down converted), I-LINK for use with HDVTM systems, and computer XGA. Other features include an "Image Flip" function for installation flexibility and up to 16 presets for operational ease of use. With these exceptional features, the BRC-H700 is ideal for a wide range of high-definition shooting applications. It is also highly suitable for remote shooting in which images are displayed on large-screen displays, such as in Studios, in auditoriums, teaching hospitals, in corporate boardrooms, and at sporting events, trade shows, and concerts.

The BRC-H700 can also be used for distance-learning applications in which clear, high definition images are required, for example, when presenting on chalkboards or white boards. Furthermore, it is an excellent choice for broadcast applications, such as the recording of television programs or as a weather camera. For these and many more applications, make the BRC-H700 your high-definition camera of choice.

2. Main Features.

BRC-H700

2.1. Stylish and Robust body with HD 3CCD.

The BRC-H700 incorporates three 1/3-type HD Interline transfer CCD, each with a total of approx: 1.12 Mega pixels.

Thanks to these CCDs and a Carl Zeiss Vario-Sonnar T* Lens which delivers high performance in every respect, superb HD picture quality can be acquired. The BRC-H700 incorporates a pan/tilt function and a high precision auto focus zoom lens into a stylish robust body. BRC-H700 can be installed easily, where space is limited and would prove difficult for the combination of a larger camera with lens and a pan-tilt head. This stylish and unobtrusive design will compliment any décor.

2.2. Wide Angle and High Accurate Pan/Tilt Mechanism.

The BRC-H700 has one of the widest ranges in its class: a pan range of 340 degrees and a tilt range of 120 degrees. The full 340 degrees pan range can be driven within 8 seconds, and the +90 degrees to -30 degrees tilt range can be driven within 4.5 seconds at it's fastest. Fastest pan/tilt speed is 60 degrees/sec. The slowest pan/tilt speed is 0.25 degree/sec. Thanks to the newly designed pan/tilt mechanism, the BRC-H700 allows the capture not only a fast moving object but also a slow moving object without any vibration. The minimum angle of pan/tilt drive is 0.0048 degrees in both pan and tilt motion (0.0048 degrees/STEP). The accuracy of the stop position is less than 0.15 degrees in both aspects.

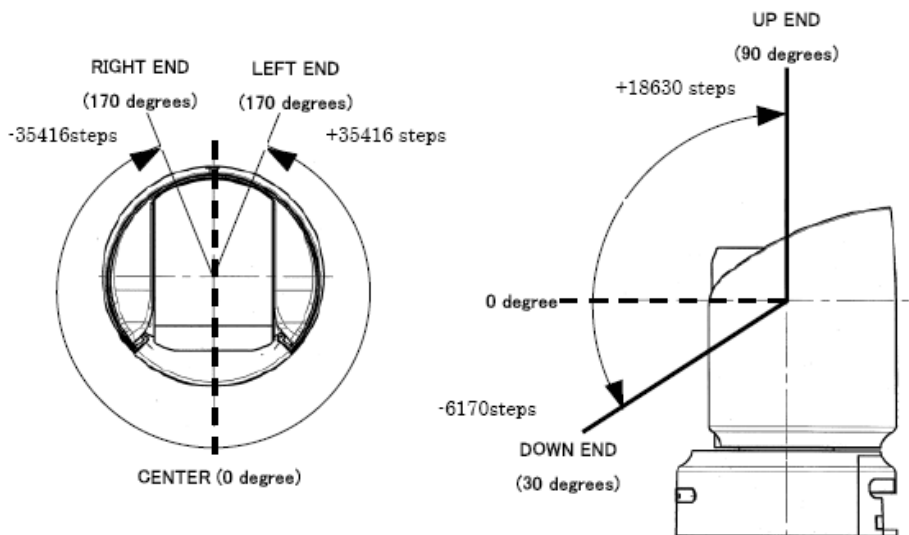

2.3. 48x Zoom Ratio (12x Optical, 4x Digital).

Direct zoom position, zoom speed selection (8 steps), and ON/OFF switch of digital zoom can be controlled by VISCA command. Moreover 1.5x and 2x digital zoom ON/OFF can be selected as well as 4x digital zoom ON/OFF as a maximum digital zoom ratio.

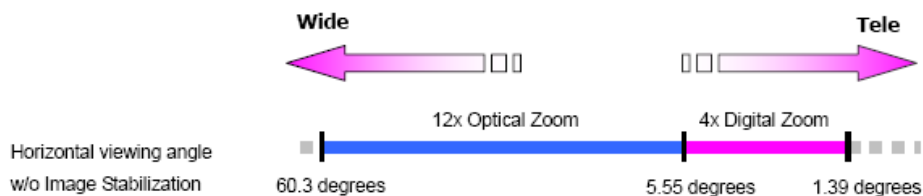

2.4. Ceiling Mounting and Image Flip Function.

The BRC-H700 can be installed on the ceiling with the supplied ceiling bracket so that you can install the BRC-H700 in a position where it can acquire the best picture.

*Note1: For details, refer to appendix The Image Flip function that flips the image upside down that allows the unit to be mounted on the ceiling, broadening the range of uses for this versatile camera.

*Note2: If you set the Image Flip to ON after turning on the power, the image will not be flipped.

Turn the power off, then on again, and the image will be flipped approx. 7 seconds later, which means that you need to restart the camera for Image Flip to be activated. The BRC-H700 is preset to face forward whenever a command from remote control equipment is sent. You can easily face the camera in the opposite direction from the normal position. In such a case, the direction of the camera can be changed while it is mounted on the ceiling. This allows for stress-free operation even in ceiling mount condition.

*Note: Installation location should be within ± 15 degrees from horizontal surface



2.5. Preset Memory Function.

When the power is turned on, the settings retained in POSITION 1 will be called up as initial settings. The memory presets are divided into two due to the difference between configurations required by Presets. Frequently changed configuration can be set in all the Preset memory from 1 to 16, and infrequently changed configuration is stored only in Preset memory1.

12x Optical Zoom 4x Digital Zoom 60.3 degrees 5.55 degrees 1.39 degrees
Horizontal viewing angle w/o Image Stabilization.

*Note 1: When turning on the power the stored settings in Preset Memory 1 is automatically activated. Required Pan/Tilt position when turning on the power should be stored in Preset Memory 1.

*Note 2: When setting preset position and calling up by RM-BR300, lower positions of buttons (9-16) are operated by pressing the Shift key at the same time.

2.6. RS-232C/RS-422 Serial Control by VISCA.

All of camera and pan/tilt functions can be controlled via VISCA commands with a remote controller or a PC. This camera incorporates the VISCA Mini DIN 8pin connectors for RS-232C control. Additionally, the dedicated 9pin connector is incorporated for RS-422 control from a remote location. RS-232C can operate up to 15m (50feet) and RS-422 is up to approximately 1.2km (4,000feet). The data transmission speed of the RS-422 and the RS-232C can be selected either 9600bps or 38400bps. As regards to daisy chain of each camera, it is possible to support up to 7 cameras with either RS-232C or RS-422.

2.7 Preset Memory and Default Value.

Preset Memory 1: All the configurations can be stored.

Preset Memory 2 to 16: Frequently changed configuration can be stored

Infrequently changed configurations cannot be stored.

Category	Mode/Position	Default	Preset Memory 1	Preset Memory 2 to 16
Pan/Tilt	Pan/Tilt position	Home	Yes	Yes
	Pan limit position	+/-170 degrees	Yes	No
	Tilt limit position	+90 degrees, -30 degrees	Yes	No
	Ramp Curve	Mode 2	Yes	No
Zoom	Zoom position	Wide-end	Yes	Yes
	Digital zoom limit	x2	Yes	Yes
Focus	Focus mode auto/manual	Auto	Yes	Yes
WB	WB mode	Auto	Yes	Yes
	Auto WB Sence	MID	Yes	Yes
	Auto WB Shift	0	Yes	Yes
	One Push WB Shift	0	Yes	Yes
	Manual WB R Gain	-90	Yes	Yes
	Manual WB G Gain	-60	Yes	Yes
Color	Gain	0	Yes	Yes
	Hue	0	Yes	Yes
AE	AE mode	Full Auto	Yes	Yes
	AE Speed (Full Auto)	MID	Yes	Yes
	AGC limit (Full Auto)	18dB	Yes	Yes
	Iris limit (Full Auto)	F11	Yes	Yes
	Gain (Manual/Gain pri)	0dB	Yes	Yes
	Shutter (Manual/Shutter pri)	1/59.94 sec (59.94i) 1/50 sec(50i)	Yes	Yes

SONY

	Iris (Manual/Iris pri)	F2.8	Yes	Yes
	Back Light on/off	Off	Yes	Yes
	ExpComp on/off	Off	Yes	Yes
	ExpComp Level	0	Yes	Yes
	Spot Light on/off	Off	Yes	Yes
Picture	Detail	10	Yes	Yes
	Skintone Detail	Off	Yes	Yes
	Gamma Normal/Cinema	Normal	Yes	Yes
	Flicker Cancel on/off	Off	Yes	Yes
	Steady Shot	Standard	Yes	Yes
System	B&W on/off	Off	Yes	No
	Color Bar on/off	Off	No	No
	IR Receive on/off	On	Yes	No
	IMG-Flip on/off	Off	Yes	No
	Pan Reverse on/off	Off	Yes	No
	Tilt Reverse on/off	Off	Yes	No
	Display Info on/off	On	Yes	No
	Analog Out	Y/Pb/Pr	Yes	No
	Sync Type (for D-sub 15pin) Three state/VD	Three state	Yes	No
	Add SYNC (only Analog RGB) to R/G/B on/off	On	Yes	No

*1: The configuration of power on status needs to be set in Preset Memory 1

*2: VISCA address is set by Camera Number Setting switch on the bottom of the BRC-H700. 0 in VISCA address column indicates that the VISCA address is set automatically. 1 to 7 indicates that the VISCA address from 1 to 7 is set at Camera No. 1 to 7. For detail, refer to Connection/Pin assignment on the following pages.

*3: IR-Receive on/off setting command cannot be implemented from the supplied IR remote commander.

2.8. RS-232C/RS-422 Serial Control by VISCA™.

All of camera and pan/tilt functions can be controlled via VISCA commands with a remote controller or a PC. This camera incorporates the VISCA Mini DIN 8pin connectors for RS-232C control. Additionally, the dedicated 9pin connector is incorporated for RS-422 control from a remote location. While the RS-232C is extended up to 15m (50feet) officially, the RS-422 is up to approximately 1.2km (4,000feet). The data transmission speed of the RS-422 and the RS-232C can be selected either 9600bps or 38400bps. As regards to daisy chain of each camera, it is supported up to 7 cameras either RS-232C or RS-422.

2.9. External synchronization capability.

This synchronization signal can be selected from standard sync, RGB three-state sync, Y three-state sync and SD-sync.

2.10. Camera control function

2.10a. Electric Shutter Speed.

The Electric shutter speed in the CCD imager enables the capture of clear images of moving objects. The shutter speed can be manually selected from a wide range of speeds (16 steps, up to 1/10,000sec). By adjusting the shutter speed, you can obtain flicker-free images even in fluorescent lighting conditions.

2.10b. Spot Light

When shooting a face or object under high luminance / incident light, the BRC-H700 can prevent the face or object colour from whitening.

2.10c. Backlight Compensation.

When shooting an object with the light source behind the object or an object with a light background, the Backlight compensation function can compensate and remedy any false exposure.

2.10d. White Balance.

The BRC-H700 adjusts white balance automatically in response to the light conditions, so that pictures with an appropriate colour balance can be always obtained. The white balance menu has the following 5 modes (Auto/Indoor/Outdoor/One push WB/Manual WB). One-push AE adjusts the white balance according to the light source. Color temperature of Indoor mode is fixed at 3200K and Outdoor mode is fixed at 5800K.

SONY

2.10e Aperture Control.

Aperture control adjusts and enhances the edges of objects in the picture. There are 16 levels of adjustment. For instance, when shooting text or fine print, Aperture control will help by making the text sharper.

2.10f. Hyper Gain.

BRC-H700 can effectively shoot an object with colour in extremely dark conditions. Hyper Gain (+30dB) is especially useful in environments or situations where lighting is not possible.

2.10g. Skin tone Level.

The enhancement of skin colour can be suppressed by setting skin tone level (4steps).

2.10h. Cinema tone Gamma.

The BRC-H700 possess a special gamma feature –the Cinema tone Gamma- which produces a gamma curve with similar contrast characteristics to a film gamma curve.

2.10i ND filter.

ND filter that is equivalent to approx. 1/6 (ND1) or approx. 1/32 (ND2) and can be set mechanically depending on amount of incidental light.

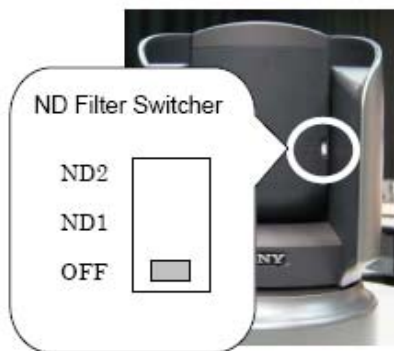

2.10j Image Stabilization.

When using the BRC-H700 in an environment with adverse vibration, using the Optical Image Stabilization system can greatly reduce picture blurring.

2.10k Color Bar.

A customer can adjust the colour settings by viewing the colour bars created by the BRC-H700.

SONY

2.11. Multi-function IR Remote Commander® unit.

The supplied remote commander unit is user-friendly and useful for basic pan/tilt/zoom camera control.

2.12. On-screen menu.

The on-screen menu allows for quick and easy picture adjustments and settings.

2.13. VISCA address setting.

The BRC-H700 can address VISCA numbers for the switching of cameras automatically as well as manually by using the DIP switches on the bottom of the BRC-H700.

3. BRU-H700

3.1 Uncompressed digital transmission.

The BRU-H700 features uncompressed multiple signal operation via a single cable. Video, sync, pan/tilt control, camera control signal and audio line-in signal can be transmitted using with the CCFC-M100HG, HD optional fiber cable and the BRBK-H700, HD optical multiplex card. The distance between the BRC-H700 and the BRU-H700 can be extended to a maximum 1,000m (3,280 feet). The Single cable operation makes it possible to integrate the camera system easily.

3.2. Various video signal output.

The BRU-H700 is equipped with analog RGB or Y/Pb/Pr signal output as standard. Furthermore, 2 built-in optional card slots enable various signals outputs in order to broaden the range of applications. For instance, an output for computer XGA can be provided from the BRU-H700 by installing the HFBK-XG1 into the slot. Also installing the HFBK-HD1 into the slot can provide HD-SDI signal. Two of the same cards can be installed into BRU-H700 at the same (except HFBK-TS1).



3.3 RS-232C/RS-422 Serial Control by VISCA™.

All of camera and pan/tilt functions can be controlled via VISCA commands with a remote controller or a PC. This camera incorporates the VISCA Mini DIN 8pin connectors for RS-232C control. Additionally, the dedicated 9pin connector is incorporated for RS-422 control from a remote location. While the RS-232C is extended up to 15m (50feet) officially, the RS-422 is up to approximately 1.2km (4,000feet). The data transmission speed of the RS-422 and the RS-232C can be selected either 9600bps or 38400bps. As regards to daisy chain of each camera, it is supported up to 7 cameras either RS-232C or RS-422.

4. BRBK-H700

4.1 HD Optical Multiplex Card.

The BRBK-H700 provides High quality optical multiplex HD signal and audio line-in signal when installed into the BRC-H700 built-in card slot.

4.2. Audio Line Input.

The BRBK-H700 is equipped with RCA Analog terminals for Audio input. By installing the BRBK-H700 into the BRC-H700, image signal of BRC-H700 and analog audio signal received by BRBK-H700 can be simultaneously transferred to BRU-H700 via HD Optical fiber cable. This is effective when a microphone is being used near the BRC-H700 and the BRU-H700 is located with the operator some distance away. This enables both the image and the audio to arrive at the same time, and also when HFBK-TS1 (HDV board) is installed into BRU-H700 and needs the image as well as the audio.

5. CCFC-M100HG.

5.1 HD Optical fiber cable.

The CCFC-M100HG is an HD optical fiber cable for connecting the BRC-H700 (with BRBK-H700) to the BRU-H700. The CCFC-M100HG is able to transmit uncompressed digital data without any deterioration. The CCFC-M100HG can be extended up to 1000m (3,280 feet) using with supplied cable extension adaptor.



6. Sales points.

BRC-H700

1. All-in-one stylish robotic camera.
2. Superb picture quality from 1/3 type HD 3-CCDs
3. Carl Zeiss Vario-Sonnar T* Lens with high quality picture representation.
4. Highly accurate Pan/Tilt mechanism
5. Built-in Auto Focus 48x zoom (12x Optical, 4x Digital)
6. Upright and Ceiling-mount installation
7. Wide system configuration with optional interface cards
8. External sync input
9. 16 position presets
10. RS-232C/RS-422 serial control (VISCA protocol)
11. Daisy chain capability (up to 7 units)
12. Image stabilization function that reduce image blurring
13. ND filter that can adapt incidental lighting
14. Multi-function IR Remote Commander® unit
15. OSD (On-Screen Display)

BRU-H700

1. Various signal outputs via two interface card slots
2. Simple single cable operation of BRC-H700 via optical fibre cable
3. RS-232C/RS-422 serial control (VISCA protocol)
4. Daisy chain capability (up to 7 units)
5. External sync input

BRBK-H700

High quality optical multiplex HD signal output

CCFC-M100HG

Enables HD signal to extend up to 1,000m in hundreds of meters

7. Applications.

7.1 Remote TV Production.

In today's ever increasing demands on television production to be something different, there is a huge requirement to place cameras in situations where it is not possible to have an operator. In this area the use of remote cameras is becoming extremely popular. This is often the case in "Reality TV" shows.



7.2 Corporate.

Business requirements offer a great opportunity for the BRC-H700 camera system. Keeping records of boardroom meetings and corporate



7.3 Governmental and Industrial.

Remote cameras are a frequent requirement in industrial and governmental scenarios. The uses can be from monitoring to achieving important events. These situations require the use of remote cameras, as there is often no room or budget to have multiple camera operators. More recently governments have started to broadcast the ceremonies that are held with their parliament buildings.



Industrial monitoring has an acute need for remote camera systems as it is often too dangerous or expensive to have camera operators in an area that requires recording or monitoring.



7.4 Events Recording and Production.

www.sonybiz.net/media

SONY

In today's commercial world the BRC-H700 offers an ideal solution to Theatre companies and show production companies. It enables the recording of a show for future evaluation and the common after show DVD sales.

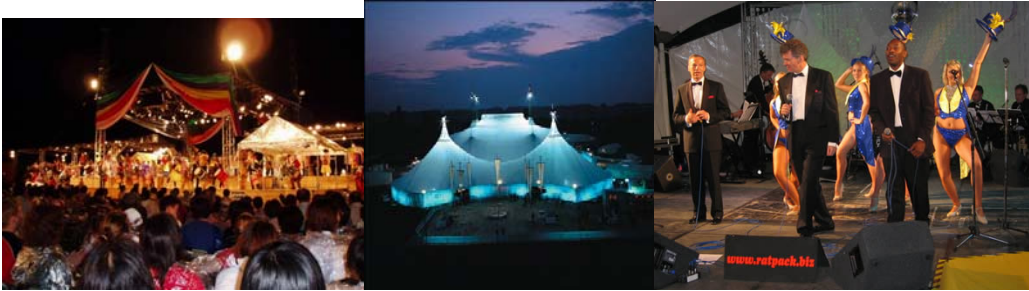

7.5 Point of View

The BRC-H700 can be used in a huge array of areas and this is its greatest benefit. From a single point of view camera (Weather cam) to a multi angle, multi camera scenario for sports.



8. System Configurations.

www.sonybiz.net/media

8.1 Simple Operation Using the Remote Commander.

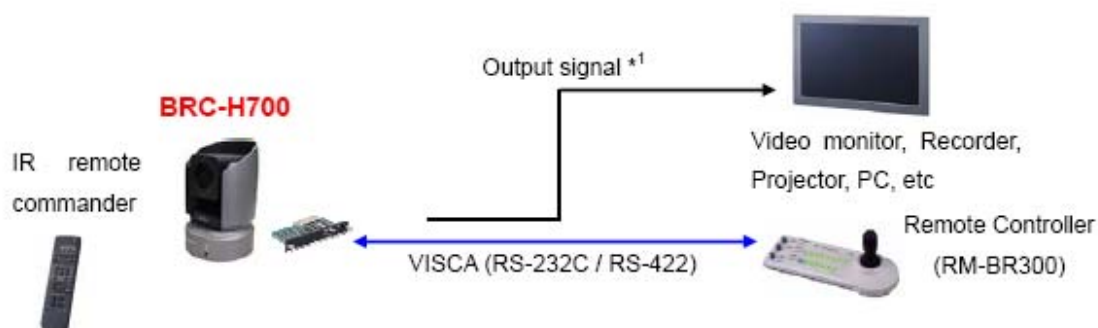

Output signal (*1)

- (Built-in) Analog RGB, Analog Y/Pb/Pr
- Optional board
 - HFBK-HD1 (HD-SDI Card): Analog RGB, Analog Y/Pb/Pr, HD-SDI x2
 - HFBK-TS1 (HDV Card)
 - HFBK-XG1 (XGA Card): WXGA, XGA, VGA
 - HFBK-SD1 (Down Converter Card): Down converted SD (RGB, Y/Cb/Cr, Y/C, Composite, SDI x2)

8.2 Simple Operation Using the Optical Multiplex Unit.

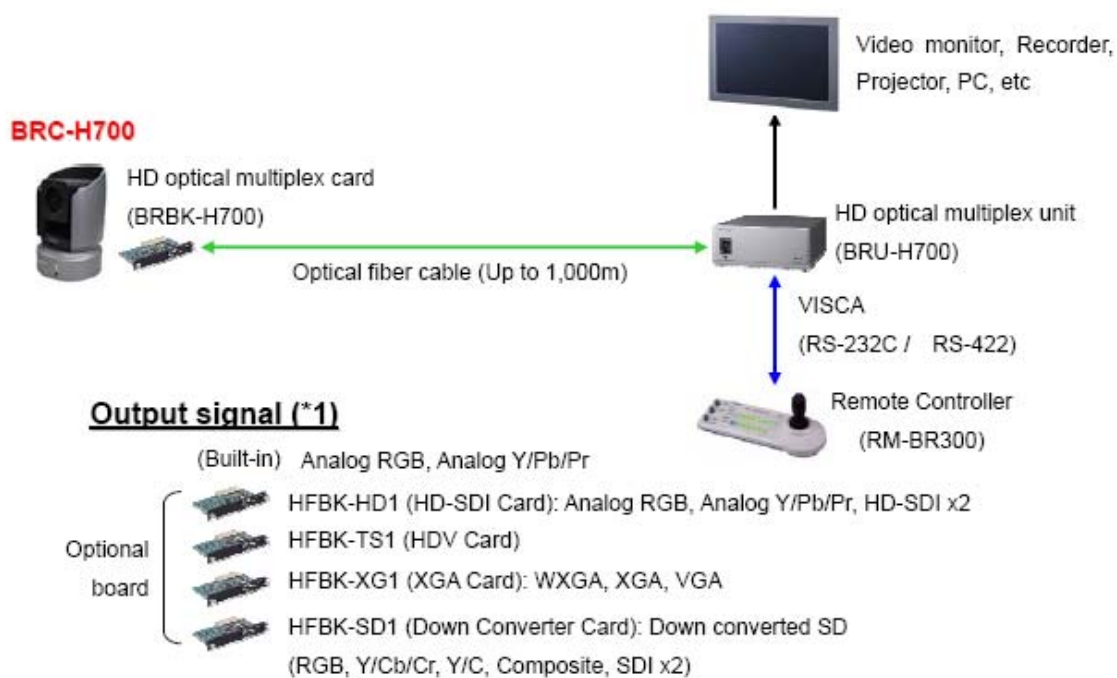

8.3 Long Distance Operation Using Multiple BRU-H700.

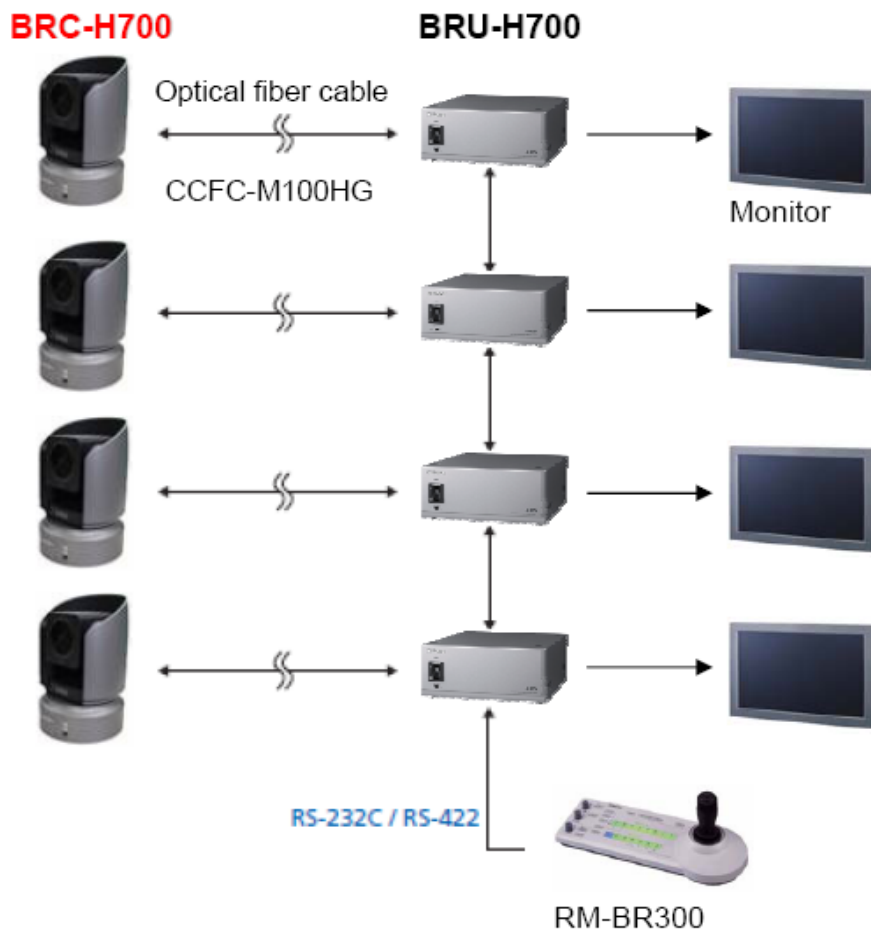

8.4 Audio Configuration.

www.sonybiz.net/media

1. **BRC-H700**



2. **BRC-H700**

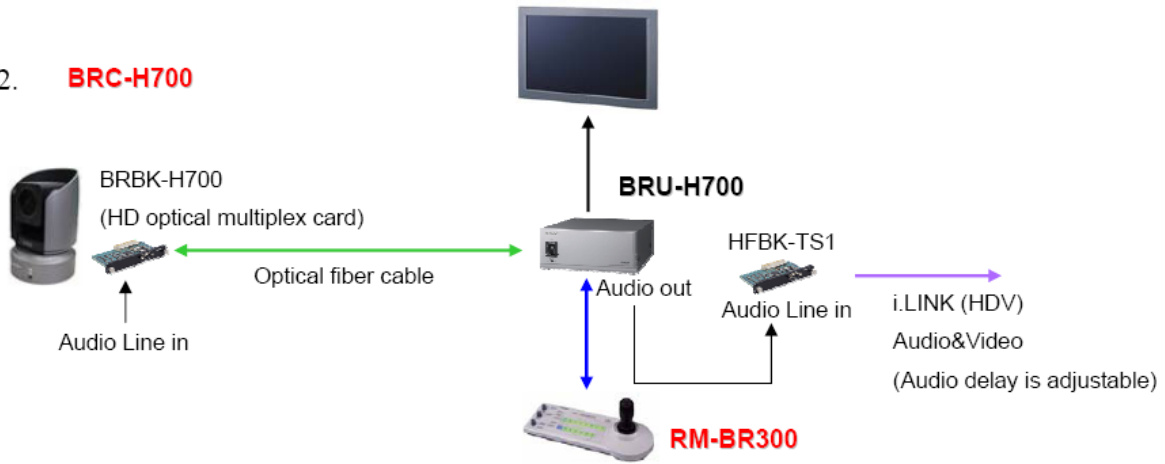

3.

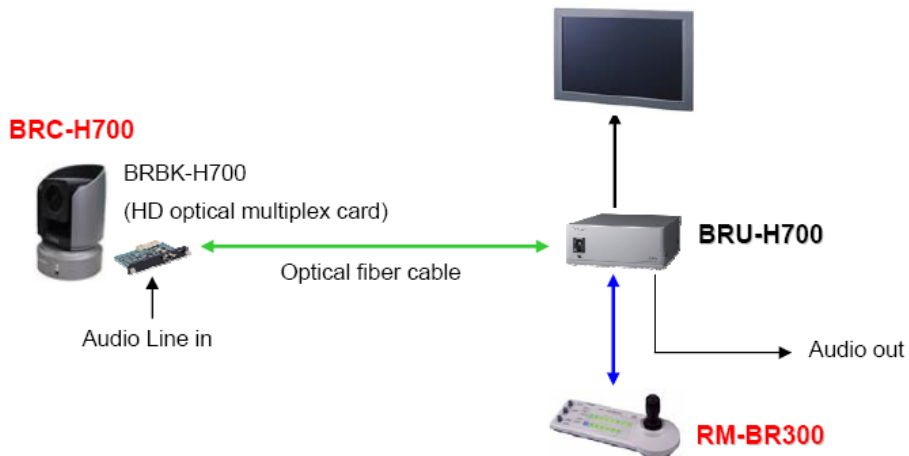

9. Main Menu Overview.

Menu Configuration

					Default value
EXPOSURE	MODE	FULL AUTO	AE SPEED	LOW,MID,HIGH	MID
			AGC LIMIT	0dB,3dB,12dB,18dB,OFF	18dB
			IRIS LIMIT	F3.4,F4.0,F5.6,F11	F11
	MANUAL	GAIN		0dB,3dB,6dB,9dB,12dB,15dB,18dB	0dB
			B.HYPER		
		SPEED		1/60,1/90,1/100,1/125,1/180,1/250,1/350,1/500,1/725,1/1000,1/1500,1/2000,1/3000,1/4000,1/6000,1/10000(59.94)	1/60
				1/50,1/75,1/100,1/120,1/150,1/215,1/300,1/425,1/600,1/1000,1/1250,1/1750,1/2500,1/3500,1/6000,1/10000(50)	1/50
	SHUTTER Pri	SPEED		F1.8,F1.7,F1.8,F2.0,F2.2,F2.4,F2.8,F2.8,F3.1,F3.4,F3.7,F4.0,F4.4,F4.8,F5.2,F5.6,F6.2,F6.8,F7.3,F8.0,F9.6,F10,F11,CLOSE	F2.8
				1/60,1/90,1/100,1/125,1/180,1/250,1/350,1/500,1/725,1/1000,1/1500,1/2000,1/3000,1/4000,1/6000,1/10000(59.94)	1/60
	IRIS Pri	IRIS		F1.8,F1.7,F1.8,F2.0,F2.2,F2.4,F2.8,F2.8,F3.1,F3.4,F3.7,F4.0,F4.4,F4.8,F5.2,F5.6,F6.2,F6.8,F7.3,F8.0,F9.6,F10,F11,CLOSE	F2.8
				1/60,1/90,1/100,1/125,1/180,1/250,1/350,1/500,1/725,1/1000,1/1500,1/2000,1/3000,1/4000,1/6000,1/10000(59.94)	1/50
	GAIN Pri	GAIN		0dB,3dB,6dB,9dB,12dB,15dB,18dB	0dB
	EX-COMP	ON/OFF			OFF
	LEVEL	-7,-6,-5,-4,-3,-2,-1,0,+1,+2,+3,+4,+5,+6,+7			0
	BACK LIGHT	ON/OFF			OFF
SPOT LIGHT	ON/OFF			OFF	
COLOR	WHITE BALANCE	AUTO	WB SENCE	LOW,MID,HIGH	AUTO, MID
		INDOOR			
		OUTDOOR			
	ONE PUSH	WB SHIFT	-7,-6,-5,-4,-3,-2,-1,0,+1,+2,+3,+4,+5,+6,+7	0	
	MANUAL	R.GAIN	-127~+127	-90	
		B.GAIN	-127~+127	-60	
COLOR GAIN	-7,-6,-5,-4,-3,-2,-1,0,+1,+2,+3,+4,+5,+6,+7		0		
COLOR HUE	-7,-6,-5,-4,-3,-2,-1,0,+1,+2,+3,+4,+5,+6,+7		0		
PICTURE	DETAIL	0,1,2,3,4,5,6,7,8,9,10,11,12,13,14,15		10	
	SKINTONE DETAIL	OFF,TYPE1,TYPE2,TYPE3		OFF	
	GAMMA	NORMAL,CINEMA		NORMAL	
	FLICKER CANCEL	ON/OFF		OFF	
	STEADY SHOT	OFF,SOFT,STANDARD,HARD		STANDARD	
	B&W	ON/OFF		OFF	
	COLOR BAR	ON/OFF		OFF	
FOCUS	MODE	AUTO,MANUAL		AUTO	
PAN TILT ZOOM	PAN-TILT LIMIT	PAN	ON/OFF	OFF	
		LEFT	170° ~ -170°	170° (END)	
		RIGHT	170° ~ -170°	-170° (END)	
		TILT	ON/OFF	OFF	
		DOWN	-30° ~ 90°	-30° (END)	
		UP	-30° ~ 90°	90° (END)	
	RAMP CURVE	MODE1,MODE2,MODE3		MODE2	
	D-ZOOM	OFF,x1.5,x2.0,x4.0		x2.0	
SYSTEM	IR-RECEIVE	ON/OFF		ON	
	IMG-FLIP	ON/OFF		OFF	
PAN-REVERSE	ON/OFF		OFF		
TILT-REVERSE	ON/OFF		OFF		
DISPLAY INFO	ON/OFF		ON		
ANALOG OUT	RGB,YPbPr		YPbPr		
ADD SYNC	RGB,OFF		RGB		
SYNC TYPE	3-STATE,VD		3-STATE		

SONY

9.1 Menu functions unique to BRC-H700.

BRC-H700's new function that BRC-300 does not have

EXPOSURE	MODE	FULL AUTO	AE SPEED	: Conversing speed setting of Auto Exposure
			AGC LIMIT	: Upper limit setting of AGC
COLOR	WHITE BALANCE	AUTO	IRIS LIMIT	: Upper limit setting of Iris
			GAIN	: Exposure setting prioritizing Gain
		ONE PUSH	SPOT LIGHT	: When shooting human face under strong illuminant, prevent the face color from whitening.
			WB SENCE	: Set Auto WB operation under strong red illuminant such as filament lamps and candles, and strong blue illuminant in shade outside. LOW: Increase red and blue~HIGH: decrease red and blue
PICTURE			WB SHIFT	: -7: white parts become blue~+7: becom red
			COLOR GAIN	: color strength -7:become light ~ +7:become dark
			COLOR HUE	: Hue -7:become green ~ +7: becom red
			SKINTONE DETAIL	: Type: recognizable coloration range of skin color is narrow
			GAMMA	: Gamma correction
PAN TILT ZOOM			FLICKER CANCEL	
			STEADY SHOT	: Image stabilization function (compensatevibration of specific frequency) SOFT: soft compensation~HARD: hard compensation
			COLOR BAR	: Indicate Color Bar
SYSTEM			RAMP CURVE	: When moving to PresetPosition, enable to change acceleration-deceleration curve of Pan/Tilt. MODE3 is the gentlest
			SYNC TYPE	

9.2 Option card menu overview.

			Default Value
HFBK-HD1	ANALOG OUT	YPbPr,RGB	YPbPr
	SYNC/VD	3-STATE,VD	3-STATE
	ADD SYNC	RGB,OFF	RGB
HFBK-SD1	D-SUB OUT 1	YPbPr,RGB	YPbPr
	ADD SYNC	RGB,OFF	RGB
	D-SUB OUT 2	VBS,Y/C	VBS
	IMG-SIZE	16:9[LETTER],4:3[CROP],4:3[SQUEEZE]	16:9[LETTER]
HFBK-XG1	IMG SIZE	XGA[CROP],VGA[LETTER],XGA[LETTER],VGA[CROP],WXG	VGA[LETTER]
	SYNC	OFF,ON	ON
	VD	POS,NEG	NEG

SONY

10. Dimensions.

BRC-H700

unit: mm (1inch =25.4mm)

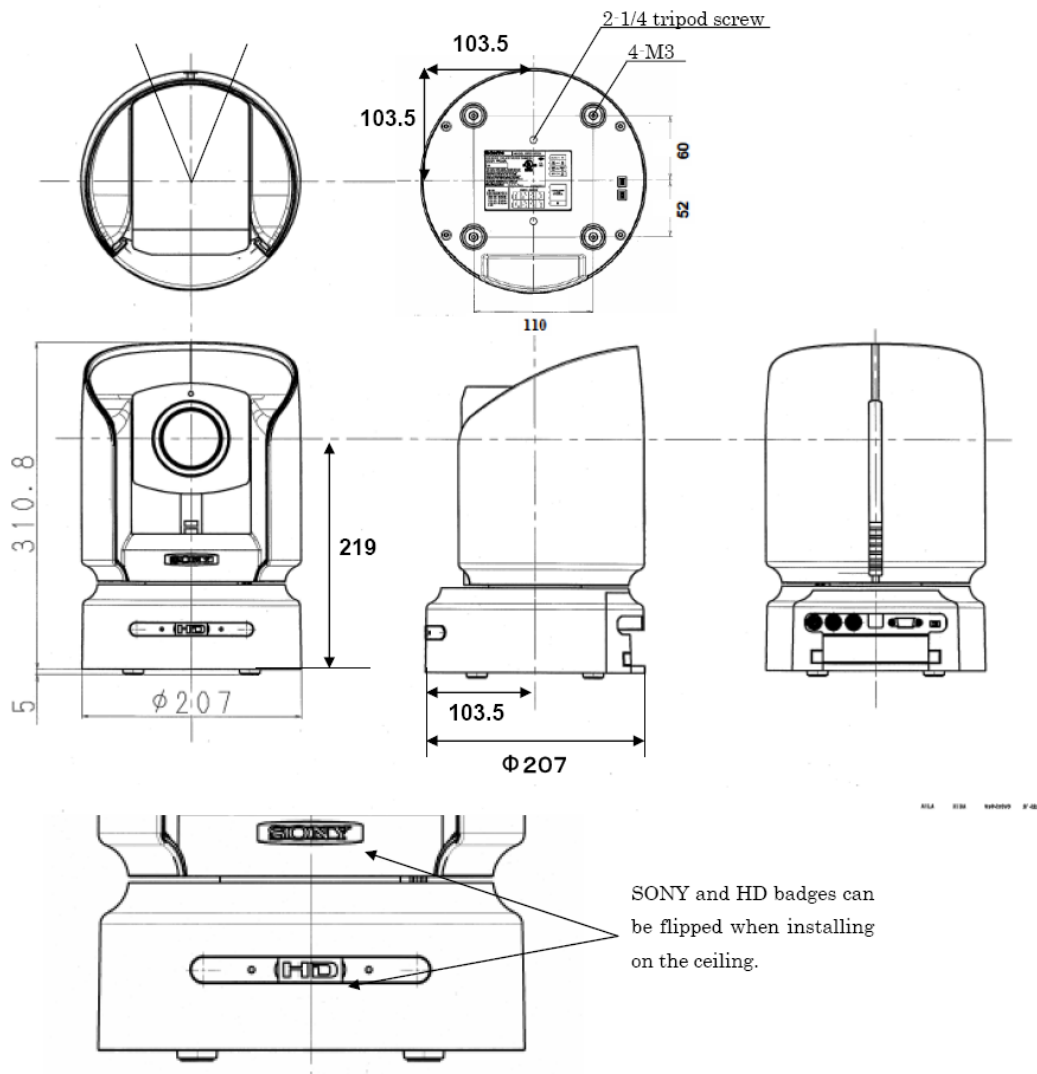

SONY

BRU-H700

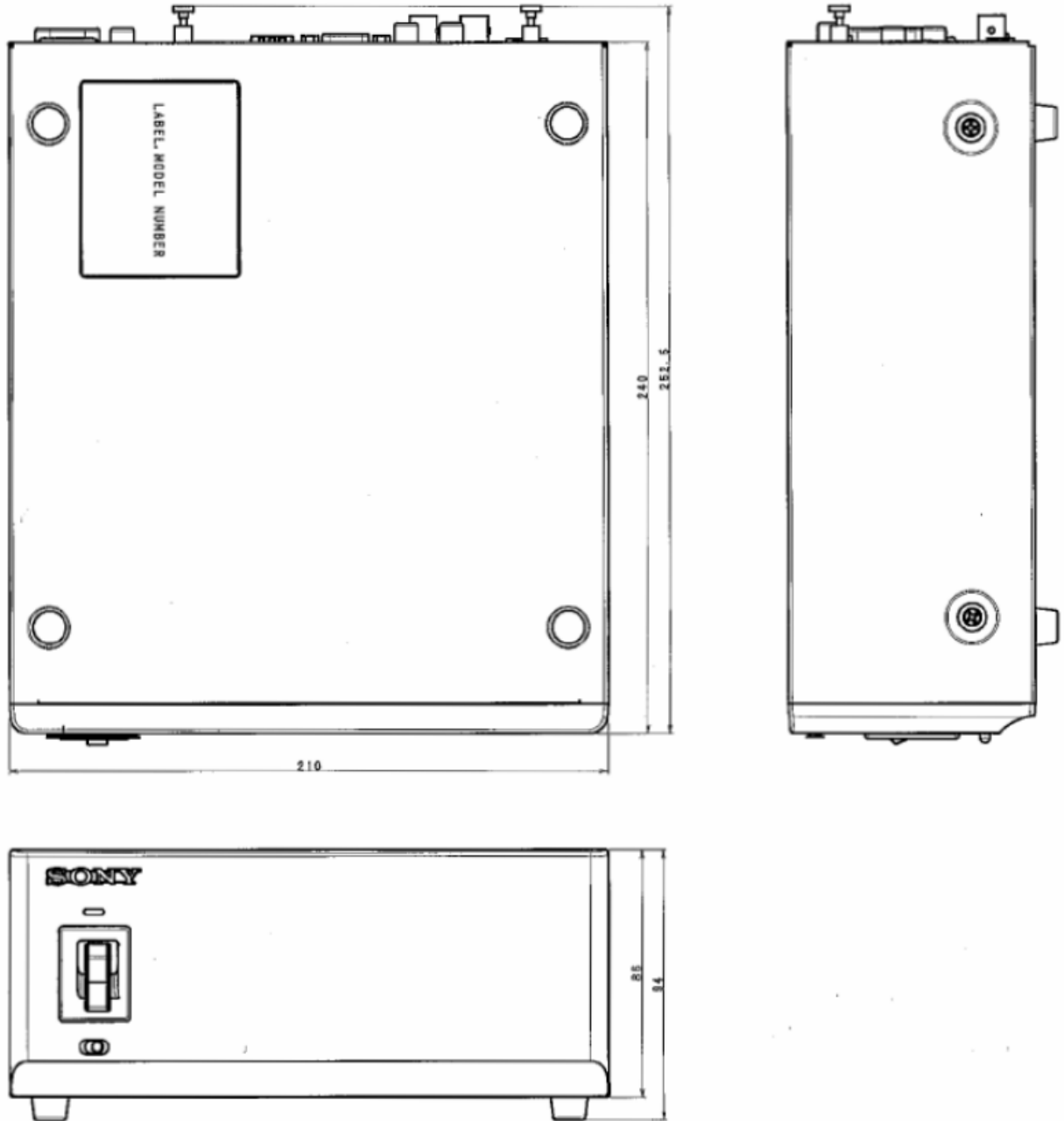

11.Rear Panel Overview.

11.1BRC-H700.

Rear Panel

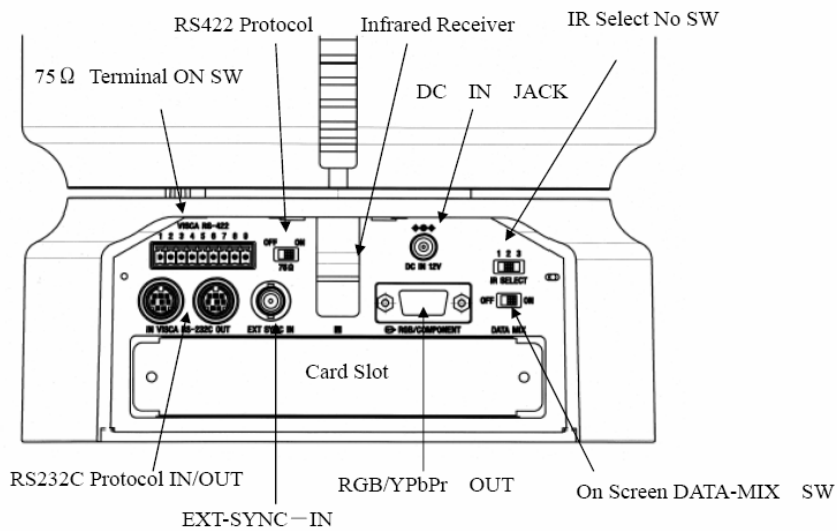

11.2 BRU-H700

Rear Panel

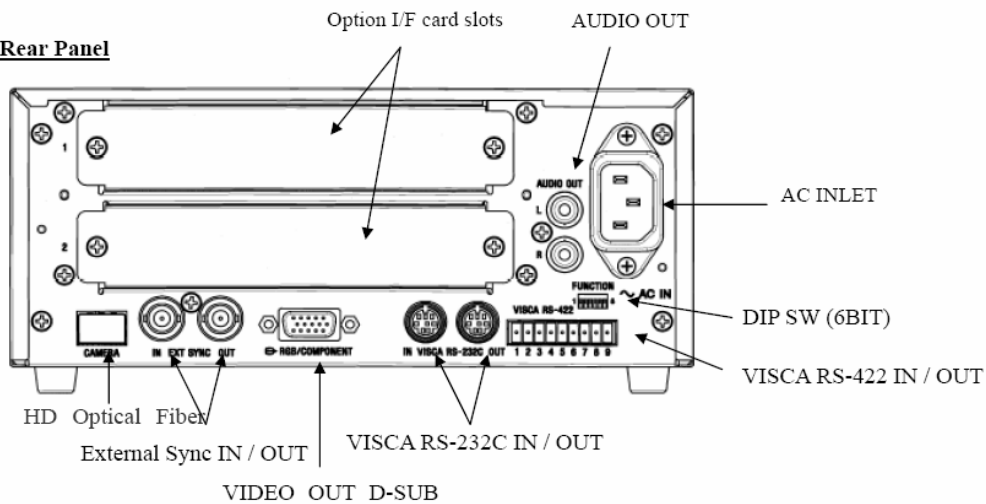

12. Specifications.

BRC-H700 HD 3CCD Color Video Camera	
Image device	Three 1/3 type IT CCDs
Total picture elements	Approx. 1.12 Megapixels
Effective picture elements	Approx. 1.07 Megapixels
Signal systems	1080/59.94i, 1080/50i (switchable)
Lens	12x optical zoom, 48x with digital zoom Carl Zeiss Vario-Sonnar T**
Focal length	f=4.5 to 54.0 mm (F1.6 to F2.8)
Minimum object distance	800 mm (Tele end)
Horizontal viewing angle without Image Stabilization	5.5 degrees (Tele) to 60.3 degrees (Wide)
Vertical viewing angle without Image Stabilization	3.1 degrees (Tele) to 36.2 degrees (Wide)
Focus system	Auto/Manual
Pan/Tilt angle	-170 to +170 degrees (Pan), -30 to +90 degrees (Tilt)
Pan/Tilt speed	0.25 to 60 degrees/s (Pan/Tilt)
Minimum illumination	6 lx (50 IRE, F1.6)
S/N ratio	50 dB
Shutter speed	1/10,000 to 1/59.94 (1/50) s
Gain	Auto/Manual (0 to 18 dB and Hyper Gain)
White balance	Auto, Indoor, Outdoor, One-push WB, Manual
Optical Image Stabilizer	On/Off
Image flip	On/Off
ND filter	Off/ND1/ND2
Preset positioning	16 positions
Video output (Built-in)	Analog RGB, Analog Y/Pb/Pr
Video output (With optional card(s))	HFBK-HD1 : HD-SDI, HFBK-SD1 : Down converted SD (RGB, Y/Cb/Cr, Y/C, Composite, SDI x2) HFBK-XG1 : WXGA, XGA, VGA, HFBK-TS1 : HDV
Camera control interface	RS-232C/RS-422 (VISCA protocol)
Backlight compensation	On/Off
Operating temperature	0 to 40 degrees (32 to 104 °F)
Storage temperature	-20 to 60 degrees (-4 to 140 °F)
Power requirements	DC 12 V
Power consumption	Max. 24 W (without optional card)
Dimensions (Diameter x H)	207 x 315.8 mm (8 1/4 x 12 1/2 inches)
Mass	4.5 kg (9 lb 15 oz)
Supplied accessories	IR Remote Commander Unit (1), RS-422 terminal block connector (1), AC adaptor (1), AC power cable (1), Ceiling bracket (2), Wire rope, Mounting screws, Operating instructions (1)

SONY

BRU-H700 HD Optical Multiplex Unit

Optical fiber connector	Multi mode, LC-type Fiber Connector
Video output (Built-in)	Analog RGB, Analog Y/Pb/Pr
Video output (With optional card : slot x2)	HFBK-HD1 : HD-SDI, HFBK-SD1 : Down converted SD (RGB, Y/Cb/Cr, Y/C, Composite, SDI x2) HFBK-XG1 : WXGA, XGA, VGA, HFBK-TS1 : HDV
Camera control interface	RS-232C/RS-422 (VISCA protocol)
Sync systems	Internal/External
Multiple connection	Up to 7 Units
Operating temperature	0 to 40 degrees (32 to 104 °F)
Storage temperature	-20 to 60 degrees (-4 to 140 °F)
Power requirements	59.94 i : AC 100 to 120 V (50/60 Hz) 50 i : AC 220 to 240 V (50/60 Hz)
Power consumption	Max. 10 W (without optional cards)
Dimensions (WxDxH)	210 (W) x 240 (D) x 86 (H) mm (8 3/8 x 9 1/2 x 3 1/2 inches)
Mass	2.7 kg (5 lb 15 oz)
Supplied accessories	AC power cable (1), RS-422 terminal block connector (1), RS-232C cable (1), Operating instructions (1)

RM-BR300 Remote Control Unit

Camera control interface	RS-232C/RS-422 (VISCA protocol)
External control	Contact closure
Power requirements	DC 10.8 to 13.2 V
Power consumption	2.4 W
Dimensions (WxDxH)	391.3 x 185 x 145.9 mm (15 1/2 x 7 3/8 x 5 3/4 inches)
Mass	950 g (2 lb 1 oz)
Supplied accessories	AC adaptor (1), AC power cable (1), RS-232C cable (3 m, 8-pin Mini Din) (1), Terminal connector (2), Operating instructions (1)

13. Optional Accessories.



BRBK-H700
HD Optical Multiplex Card
With Audio IN (RCA pin)



HFBK-HD1
HD-SDI Interface Card
HD-SDI, HD Analog RGB/
Component



HFBK-SD1
SDI Interface Card
Down Converted SD-SDI, Analog
RGB/Component/S-Video/Composite



HFBK-XG1
XGA Interface Card
WXGA XGA (Letter Box, Crop),
VGA (Letter Box, Crop)



RM-BR300
Remote Control Unit



BRU-H700
HD Optical Multiplex Unit



CCFC-M100HG
Optical Fiber Cable
2-core Multi-mode Optical Fiber
Cable (100 m long), Extension Plug
Included



CCMC-9DS
RGB/Component, Y/C Cable
(9-pin D-sub)



CCXC-9DBS
RGB/Component, VBS Cable
(9-pin D-sub)

HFBK-TS1
i.Link (HDV) Card
With Audio IN (RCA pin)

SONY